

Single Phase Shunt Active Filter with Fuzzy Controller for Harmonic Mitigation

C L Anooja, N Leena

Abstract— This paper presents a single phase shunt active filter with fuzzy controller for harmonic mitigation .Shunt active filter is an efficient method for reducing harmonic content in power system. Instantaneous pq theory is used for the generation of reference controller signal and hysteresis controller is used for the production of gate signal. In this paper a comparative assessment of the performance of the conventional PI controller and fuzzy controller for harmonic mitigation is presented. Multilevel inverters are also discussed for harmonic mitigation. The simulation results show that the proposed fuzzy controller can give superior results with lower THD when compared to the PI controller. The results also validate that as the number of inverter level increases, the performance gets improved.

Index Terms— Harmonics, Total Harmonic Distortion(THD),Multi inverter,Fuzzy logic ,PI controller,Instantaneous P-Q theory,Hysteresis current control.

1 INTRODUCTION

Power electronic devices are widely used in domestic as well as industrial application. The main disadvantage of using these devices is that they cause harmonic pollution in power system, and as a result they generate many adverse effects like reduction in the efficiency of the system, premature failure of the electrical and electronic equipment's, increase in power losses etc. Shunt active filter is one of the solutions for avoiding those types of problems created by the presence of harmonics. Active filters with fuzzy controller are superior in filtering performance, smaller in physical size, and more flexible in application, compared to traditional harmonics mitigation method. The concept used in an active filter is the introduction of current components using power electronics to remove the harmonic distortions produced by the nonlinear load. In order to obtain a clean sinusoidal supply current (I_s) the shunt active filter has to keep on injecting compensating harmonic currents to cancel the current harmonics present in the nonlinear load. The block diagram is shown in fig.1. The control of inverter strategy has three stages. In the first stage, the supply voltage and current signals are measured. In next stage, reference currents are generated based on instantaneous p-q theory. In the third stage, the gating signals for the power switches of inverter produced using hysteresis-based current control method.

The instantaneous real and reactive power can be calculated in terms of α - β voltage and current signals. Harmonic active powers are separated from instantaneous active and reactive powers by using high-pass filters. The knowledge of harmonic active and reactive powers helps us to derive the compensating currents [1-4]. Hysteresis current controller can be used to generate the switching signals of the inverter switches [5].

During non-switching operation, shunt filter charges dc capacitor through the diodes to the maximum value of system voltage. The DC side of the inverter is connected to a capacitor. The DC capacitor provides a constant DC voltage and the real power necessary to cover the losses of the system. In the steady state, the real power supplied by the source should be equal to the real power demand of the load plus a small power to compensate the losses in the active filter. Thus, the DC capacitor voltage can be maintained at a reference value. However, when the load condition changes the real power balance between the mains and the load will be disturbed. The real power difference is to be compensated by the DC capacitor. This changes the DC capacitor voltage away from the reference voltage. A PI controller is used to keep the constant voltage across the capacitor by minimizing the error between the capacitor voltage and the reference voltage. But PI controller has its own disadvantages is that it needs a precise mathematical model of the system lest the control operation of PI controller is not efficient and accurate. The conventional controllers also fail to perform satisfactorily under varying conditions. This necessitated the usage of an intelligent control technique.

In this paper, a fuzzy controller is used to overcome the problem say which problem. Multi-level inverter helps to reduce the harmonic level observed in the conventional inverter and THD reduces with the increase of the number of levels of inverter [10-14]. Fig.2 shows a two-level, three-level and five-level inverter. Here a multilevel inverter is used as a shunt active filter.

The paper is organized as follows; Section II presents the control operation of inverter which contains reference current generation based on the single phase PQ theory, fuzzy controller and hysteresis current control for producing gate signal of power switches. The simulation results of the shunt active filter with conventional PI and the proposed fuzzy controller are provided in section III. Section IV presents the conclusion of this work.

- C L Anooja is currently pursuing masters degree program in power electronics and power system in M G University, India, PH-9747262825.
E-mail: anoojaclal@gmail.com
- N Leena is currently working as Asst.Prof in the Dept of EEE at Federal Institute of Science and Technology ,Angamaly,India,

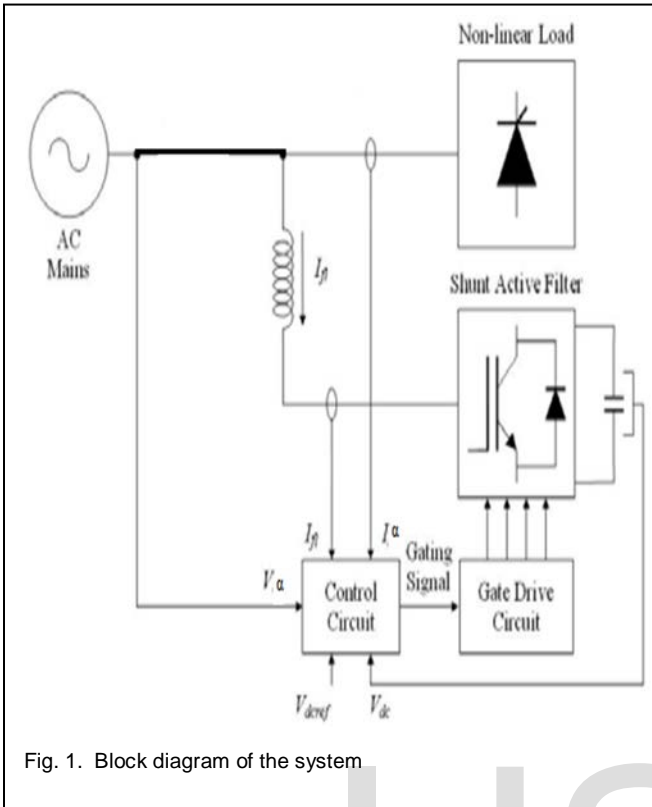

Fig. 1. Block diagram of the system

2 CONTROL OPERATION OF THE INVERTER

2.1 Reference Current Generation Based on Single Phase PQ Theory

Due to the presence of power electronic devices, the supply current contain both fundamental component and harmonic component. When active filter is connected into the system, it injects the current which is equal to the harmonic component and cancel each other, supplying pure current composed of only fundamental component. Single phase PQ theory is suitable for active filter control for reference current calculation. From the system, actual current and voltages are measured called by the 'α' component. These actual signals can be phase shifted by 90°, and called the 'β' component or pseudo component. By using 'α-β', components of voltage and current are used for the calculation of active and reactive power.

$$\begin{bmatrix} p \\ q \end{bmatrix} = \begin{bmatrix} v_\alpha & v_\beta \\ v_\beta & -v_\alpha \end{bmatrix} \begin{bmatrix} i_\alpha \\ i_\beta \end{bmatrix} = \begin{bmatrix} \tilde{p} + \check{p} \\ \tilde{q} + \check{q} \end{bmatrix} \dots \dots \dots (1)$$

The real and reactive power, consisting of harmonic and fundamental component, is separated by using a high pass filter. Fig.3 shows the block diagram for reference current generation.

\tilde{p}, \tilde{q} = Active and reactive component corresponding to the harmonic component

\check{p}, \check{q} = Active and reactive component corresponding to the fundamental component

Compensating reference current:

$$\begin{bmatrix} i_\alpha^c \\ i_\beta^c \end{bmatrix} = \begin{bmatrix} v_\alpha & v_\beta \\ v_\beta & -v_\alpha \end{bmatrix}^{-1} \begin{bmatrix} \tilde{p} \\ \tilde{q} \end{bmatrix} \dots \dots \dots (2)$$

i_β^c has no physical significance hence is discarded and i_α^c is only used as a compensation current

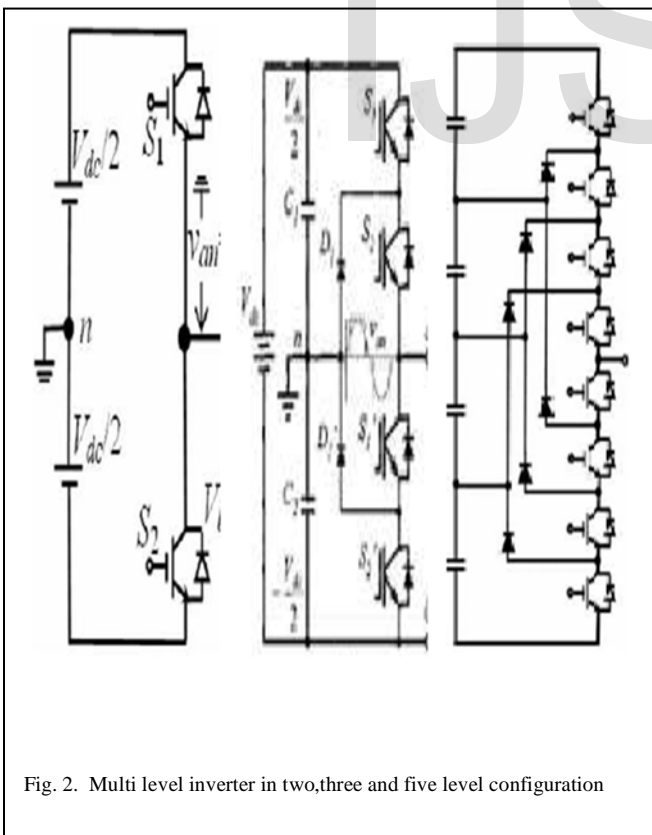

Fig. 2. Multi level inverter in two,three and five level configuration

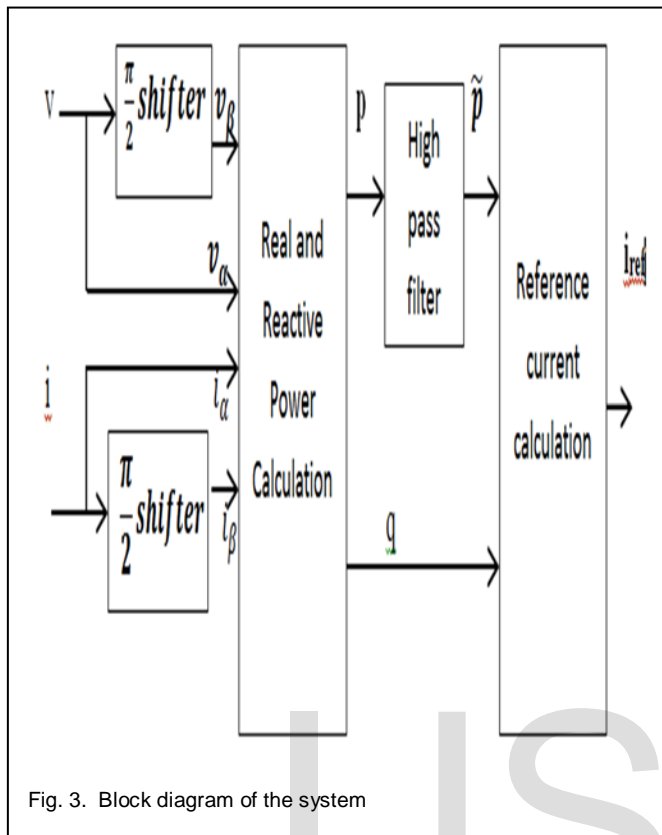

Fig. 3. Block diagram of the system

3 DC CAPACITOR VOLTAGE CONTROL

3.1 PI Controller

The PI controller consists of a proportional term and an integral term. Proportional value determines the reaction to the current error; the Integral determines the reaction based on the sum of recent errors. K_i and T_i are the proportional and the integral gains of the dc bus voltage PI controller. The Transfer function of Pi controller is

$$G_{PI}(s) = K_i \left(1 + \frac{1}{sT_i} \right) \dots\dots\dots(3)$$

Here the values of proportional and integral gain taken as 0.345, $T_i=34.9$. PI controller need a precise mathematical model of the system otherwise the control operation of PI controller is not efficient and accurate. If there are any changes occurring in the system, the existing PI controller in the system is not able to provide sufficient control of dc capacitor voltage and as a result the THD value is not reduced.

3.2 Fuzzy Controller

The advantages of soft computing controllers are that they do not require an accurate mathematical model; it can work with imprecise inputs, can handle non-linearity, and are more robust than conventional controllers.

The fuzzy controller has two inputs, one is error voltage of dc capacitor voltage and other is change of voltage (previous error - current error). These two inputs have seven Gaussian membership functions in linguistic terms, by using these function the 49 'IF THEN' rules were generated. Output of fuzzy controller is a nonfuzzy number and it is obtained by using Centre of gravity method. The rule base of the fuzzy controller is given in Table I.

TABLE I
 RULES BASE OF FUZZY CONTROLLER

		Error						
		NB	NM	NS	ZE	PS	PM	PB
ΔE	NB	NB	NB	NB	NB	NM	NS	ZE
	NM	NB	NB	NB	NM	NS	ZE	PS
	NS	NB	NB	NM	NS	ZE	PS	PM
	ZE	NB	NM	NS	ZE	PS	PM	PB
	PS	NM	NS	ZE	PS	PM	PB	PB
	PM	NS	ZE	PS	PM	PB	PB	PB

2.2 Hysteresis Current Controller

Hysteresis controller is used independently for each phase and directly generates the switching signals for the switches of inverter. The error signal is the difference between the reference current and the actual current. If the error current exceeds the upper limit of the hysteresis band, the upper switch of the inverter arm is turned OFF and the lower switch is turned ON. If the error current crosses the lower limit of the hysteresis band, the lower switch of the inverter arm is turned OFF and the upper switch is turned ON. As a result, the current gets back into the hysteresis band as in fig.4.

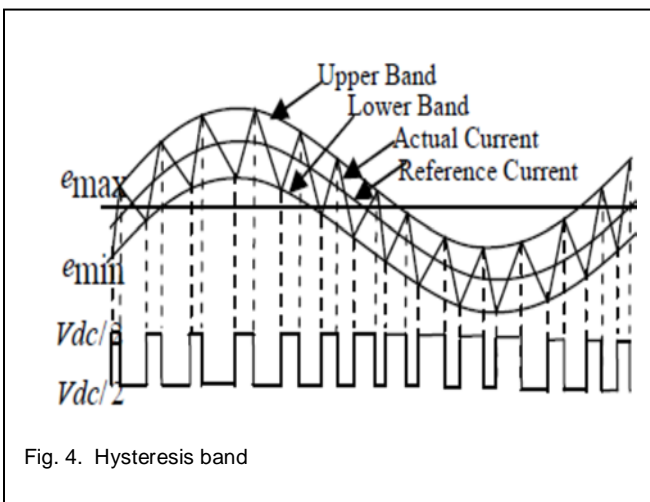

Fig. 4. Hysteresis band

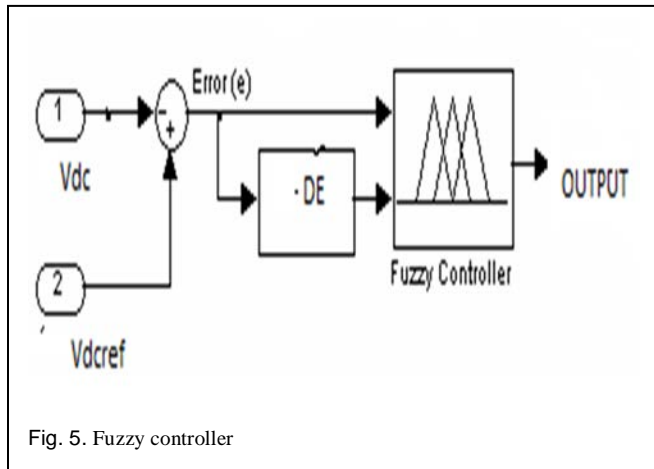

Fig. 5. Fuzzy controller

4 SIMULATION AND RESULTS

Single phase shunt active filter is simulated with PI and fuzzy controller in different multilevel configurations. The system parameters used for simulation are given in Table.II.

TABLE 2
 SIMULATION PARAMETERS

PARAMETERS	VALUES
Supply voltage	230V
Supply frequency	50Hz
Supply side inductor	5H
Supply side resistor	0.1Ω
Load resistor	20Ω
Load inductor	0.1H
Load capacitor	1mF
Reference capacitor Voltage	300V

When sudden changes occur in the system, the PI controller alone is not sufficient for controlling the dc capacitor voltage. But in the case of fuzzy controller, the THD level reduces below the IEEE standard. As the number of levels of inverter increases, the THD is also reduced.

Here load is connected as a RL load through a diode rectifier. During the simulation another RC load is connected to the system through a circuit breaker. PI controller cannot give an efficient control action due to this sudden change in the system, but the fuzzy controller can reduce the THD during the changes. Fig 6 displays the Simulink block diagram of the system.

The THD analysis of a two level shunt active filter with PI controller and fuzzy controller are shown in fig 7 and 8. Fig 9 and 10 shows the THD analysis of three level shunt active filter with PI and fuzzy controller. Five level active filter is connected to the system and THD analysis is done as shown in the fig 11 and 12.

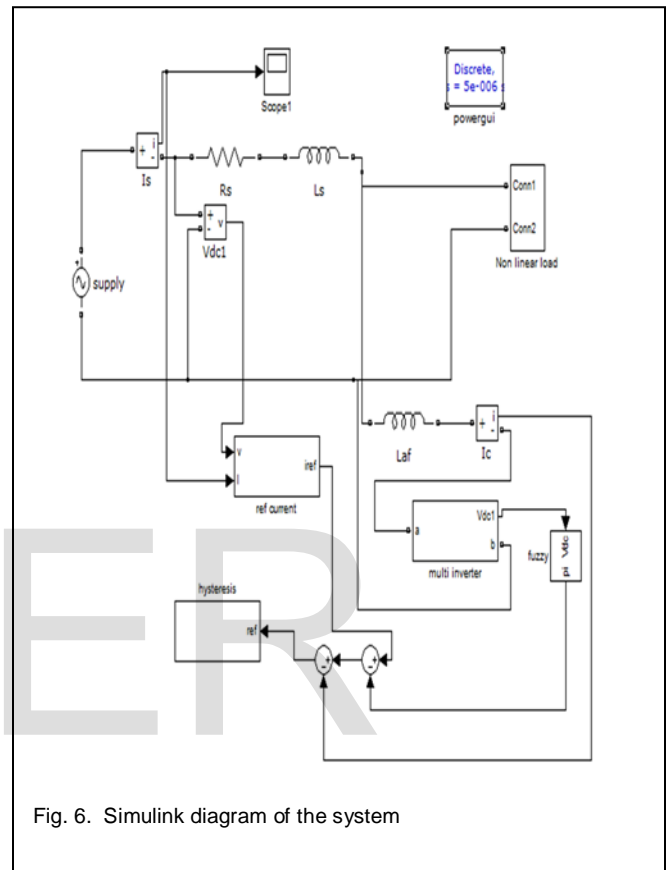

Fig. 6. Simulink diagram of the system

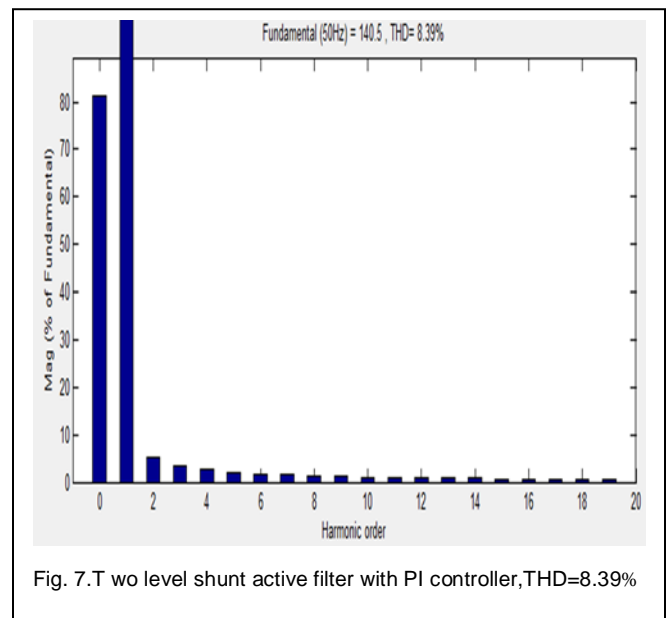
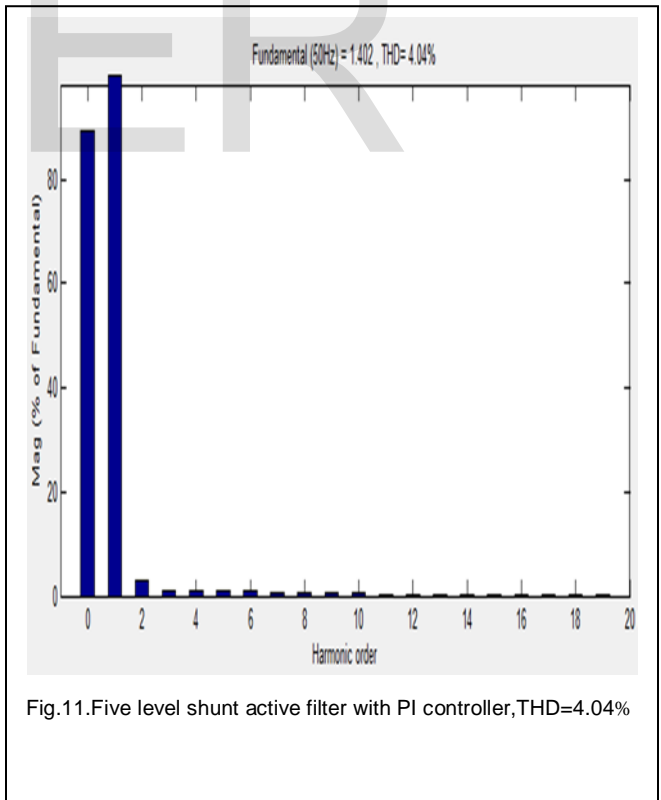
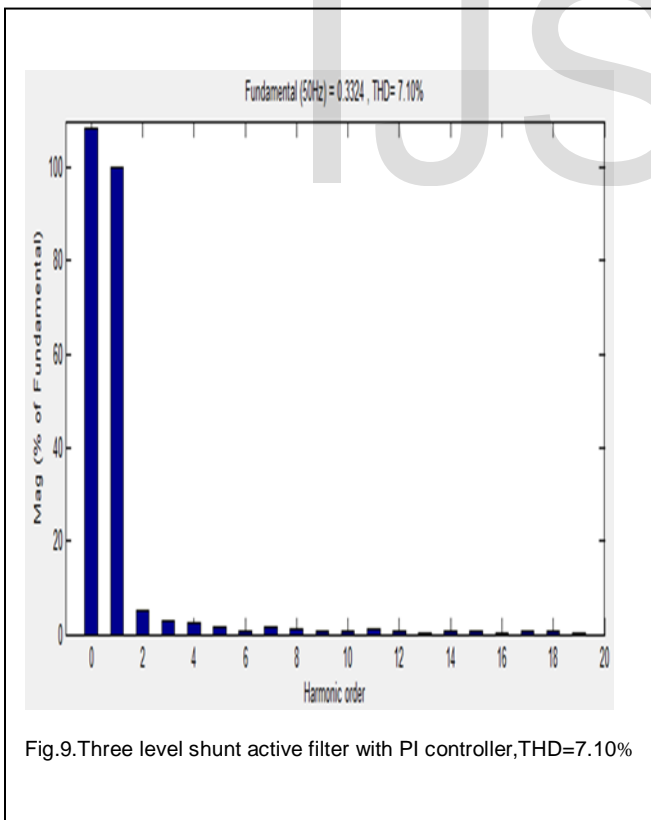
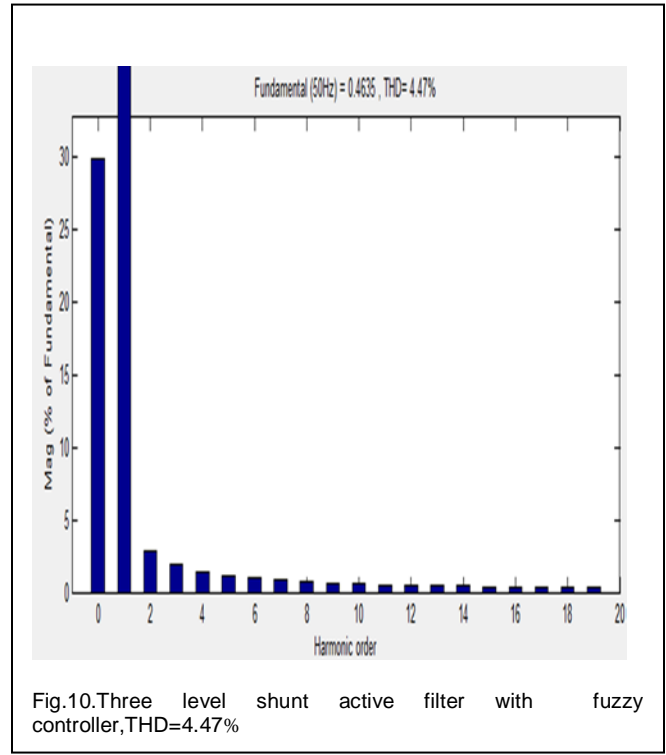
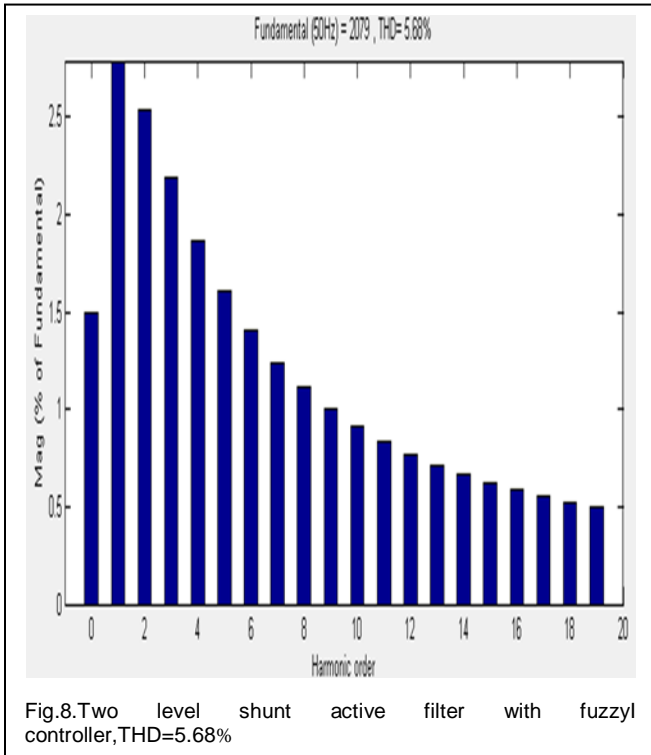
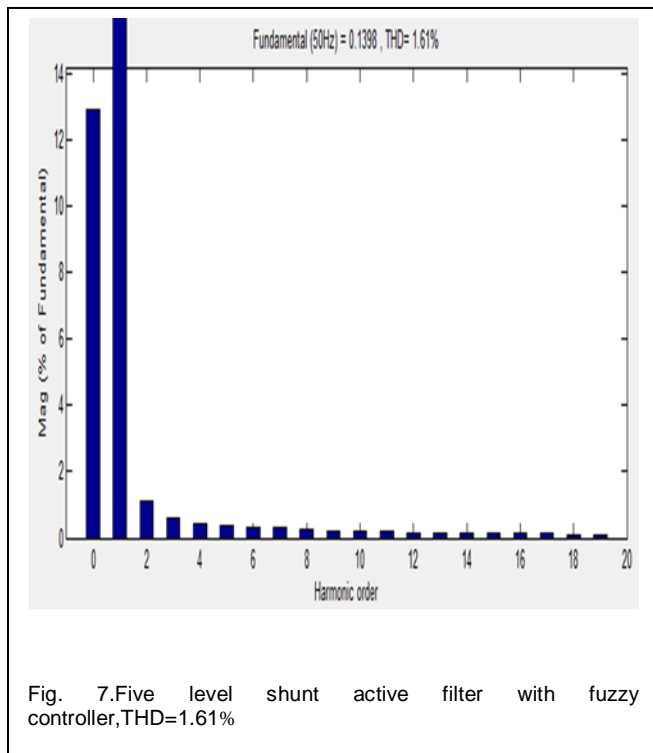

Fig. 7. Two level shunt active filter with PI controller, THD=8.39%





The simulation results of multi-level inverter are tabulated in Table III.

TABLE 3
SIMULATION RESULTS

Inverters	THD(%)	
	PI Controller	Fuzzy Controller
Two level inverter	8.39	5.68
Three level inverter	7.10	4.47
Five level inverter	4.04	1.61

The above result shows that THD gets reduced significantly on using a fuzzy controller than with the conventional PI controller. In the two level configuration, the THD level is 8.39% with PI controller and gets reduced to 5.68% upon using a fuzzy controller instead of PI. Similarly, in three level inverter, the fuzzy controller reduces the THD by 4.94% whereas with the PI controller THD is 7.10%. In the case of five level configuration with PI controller, the THD was 4.47% on the other hand a system with fuzzy controller reduces the THD to 1.61%.

5 CONCLUSION

This paper demonstrates that fuzzy controller performs better than a PI controller for harmonic mitigation. Shunt active filter was simulated in two, three and five level configuration. From the simulation result analysis, it is clear that a fuzzy controller is able to provide much better response under varying load condition. Multilevel inverters were found to be very effective in reducing the THD of the system. Hence a multi-level inverter with a fuzzy controller can effectively reduce the THD of the system.

ACKNOWLEDGMENT

We would like to thank the management, principal, HOD (EEE) and others staff members of Federal Institute of Science and Technology, Angamaly for their support and guidance in carrying out this work.

REFERENCES

- [1] H. Akagi, "New trends in active filters for power in conditioning," IEEE Proc. IEEE Trans. on Industry Applications, vol. 32, no. 6, pp. 1312-1322, Nov-Dec. 1996.
- [2] P. C. Tan, Z. Salam and A. Jusoh "A single-phase hybrid active power filter using extension p-q theorem for photovoltaic application" IEEE PEDS 2005
- [3] S.Chandrasekaran and K. Ragavan " Reference current extraction through sliding DFT filter assisted single phase p-q theory for shunt active power" International Journal of Emerging Electric Power Systems 2013; 14(2): 149-158
- [4] Juraj Altus, Jan Michalik and Branislav Pobručky "Single phase power active filter using instantaneous real power theory- theoretical and practical approach "Electrical power quality and utilization journal Vol XI, No-1, 2005
- [5] T. Narongrit, K-L. Areerak and K-N. Areerak "The comparison study of current control techniques for active power filters" World Academy of Science, Engineering and Technology 60 2011
- [6] Parmod Kumar and Alka Mahajan "Soft computing techniques for the control of an active power filter" IEEE Transactions on Power Delivery, Vol. 24, NO. 1, January 2009
- [7] G. Jayakrishna and G. Jayakrishna "Fuzzy logic control based three phase shunt active filter for voltage regulation and harmonic reduction" International Journal of Computer Applications (0975 – 8887), Volume 10–No.5, November 2010
- [8] George adam, alina georgiana stan (baci), gheorghe livinț "An adaptive hysteresis band current control for three phase shunt active power filter using fuzzy logic" 2012 International Conference and Exposition on Electrical and Power Engineering (EPE 2012), 25-27 October, Iasi, Romania
- [9] G. Jayakrishna and K.S.R.Anjaneyulu "Fuzzy logic control based three

phase shunt active filter for voltage regulation and harmonic reduction”
International Journal of Computer Applications (0975 – 8887) Volume 10–
No.5, November 2010

[10] G.H. Bode and D.G. Holmes, “Implementation of three level hysteresis current control for a single phase voltage source inverter,” 31st Annual IEEE Power Electronics Specialists Conference, Vol. 1, pp. 33-38, June 2000.

[11] Corzine, K.A “ A hysteresis current regulated control for multilevel drives”, IEEE Trans. Energy Convers., vol. 15, no. 2, pp. 169-175, 2000

[12] Jose Rodriguez, Jih-Sheng Lai and Fang Zheng Peng. “Multilevel Inverters : A survey of topologies,controls and applications.” IEEE Trans. Ind.Electronics. vol-49 no.4 pp 724-738, Aug. 2002

[13] J. Rodríguez, J. S. Lai, F. Z. Peng, “Multilevel inverters: a survey of topologies, controls, and applications,” *IEEE Transactions on Industrial Electronics*, vol.49, no.4, pp. 724-738, 2002.

[14] Z. Du, L. M. Tolbert, J. N. Chiasson, “Active harmonic elimination for multilevel converters,” *IEEE Transactions on Power Electronics*, vol. 21, no. 2, pp. 459-469, 2006.

IJSER